

Simpson S66x Counter Series Application Note



AN-6603

Flow Rate Measurement

Technical Level: Intermediate

Application Description

A Simpson Counter is to be used to measure the flow rate of product pumped from a storage tank into shipping containers.

A 'Pulse Wheel' flow gauge is used to detect the flow of liquid into the pump infeed pipe.

During pumping, a bell is to sound when flow falls below a minimum of 6 gallons per minute or above 75 gallons per minute.

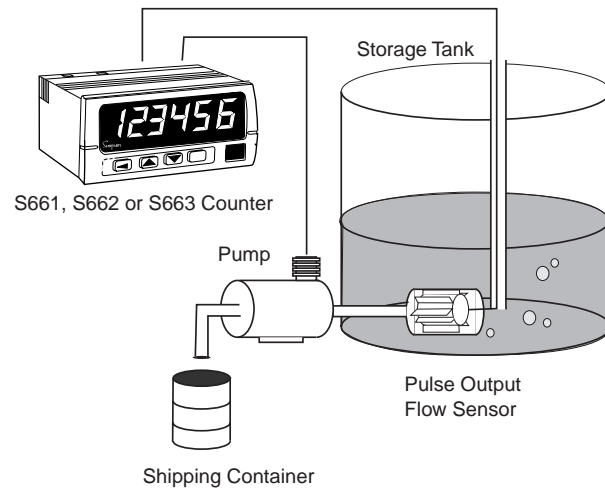

System Specifications

- Flow Gauge:** 25 pulses are generated for every gallon of liquid that passes through the sensor. The output is a high speed 'Reed' type contact.
- Pump:** An 120 VAC electric pump draws liquid from the storage tank via the Flow Gauge. The pump has a maximum pumping capacity of 100 gallons per minute with this piping arrangement. The pump runs from its own power service but is activated by a 120 VAC control signal which draws less than 0.1 Amps.
- Siren:** The alarm operates from 120 VAC at 0.5 Amps maximum.
- Display:** Desired display of flow will be in Gallons per Minute (GPM) with 1 decimal place (###.# GPM).
- Process:** Problems have occurred in the past with contaminants obstructing the flow or operators not attaching the appropriate fill nozzle. Both conditions cause the actual flow to be above or below an expected amount. Detection of these conditions will minimize maintenance expenditures.

Product Selection

Rate Counter (Simpson #S661) operating from 120 VAC power has the required capabilities. By adding the single relay option, a complete counter system has been configured.

When selecting a counter, initial computations are required to insure that maximum operation speeds will not be exceeded.

$$\text{Maximum Flow Rate} = \frac{100 \text{ Gal/Min} \times 25 \text{ Pulses/Gal}}{60 \text{ Sec/Min}} = 41.666 \text{ Pulses/Sec} = \mathbf{41.666 \text{ Hz}}$$

This is well below the S661 maximum input frequency of 20 KHz.

The siren current is well within the relay current capacity of 5 Amps.

Product Ordering Information

Qty	Simpson Part #	Description																		
1	S661-1-1-1-0-0	<table style="width:100%; border:none;"> <tr> <td style="text-align:center;">Model</td> <td style="text-align:center;">Power</td> <td style="text-align:center;">Input</td> <td style="text-align:center;">Output</td> <td style="text-align:center;">Excitation</td> <td style="text-align:center;">Other</td> </tr> <tr> <td style="text-align:center;">↓</td> <td style="text-align:center;">↓</td> <td style="text-align:center;">↓</td> <td style="text-align:center;">↓</td> <td style="text-align:center;">↓</td> <td style="text-align:center;">↓</td> </tr> <tr> <td style="text-align:center;">S661</td> <td style="text-align:center;">120VAC 1 240VAC 2</td> <td style="text-align:center;">Standard 1 Quadrature 2</td> <td style="text-align:center;">None 0 1 Relay 1 2 Relay 2</td> <td style="text-align:center;">None 0 12 VDC 1</td> <td style="text-align:center;">None 0</td> </tr> </table>	Model	Power	Input	Output	Excitation	Other	↓	↓	↓	↓	↓	↓	S661	120VAC 1 240VAC 2	Standard 1 Quadrature 2	None 0 1 Relay 1 2 Relay 2	None 0 12 VDC 1	None 0
Model	Power	Input	Output	Excitation	Other															
↓	↓	↓	↓	↓	↓															
S661	120VAC 1 240VAC 2	Standard 1 Quadrature 2	None 0 1 Relay 1 2 Relay 2	None 0 12 VDC 1	None 0															

Hardware Setup :

Using a Standard Input Card, the default settings may be used.

Since the signal is less than 100 Hz, the counter 'debounce' circuitry may be used by selecting the A Low Frequency position (switch position 5 = ON). Using this feature is recommended since the flow sensor contact could create 'dirty' edges.

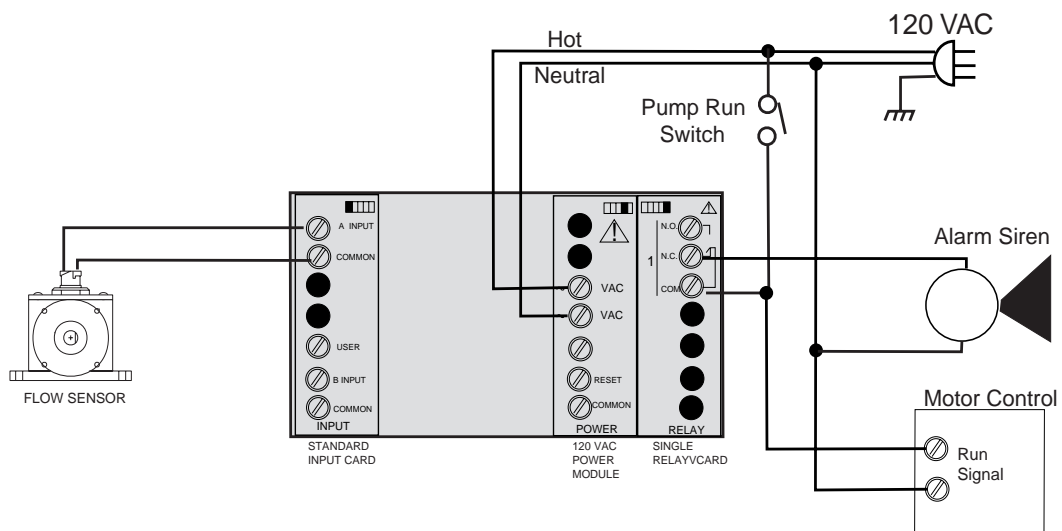
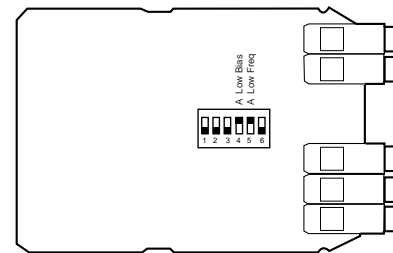

Counter Programming:

The alarm is to be activated whenever the pump control switch is on and the flow rate is above or below the specified limits. This action is the inverse of boundary operation, thus the Normally Closed (NC) relay contact is used.

Since the desired rate display is Gallons per Minute, the Minute mode will be the best choice. Scaling to Gallons from pulses is achieved by taking the inverse of the flow sensor's Pulses per Gallon specification:

$$\text{Scaling} = \frac{1}{25 \text{ Pulses/Gallon}} = 0.04 \quad (\text{Gallons/Pulse})$$

Since the display will be the nearest tenth of GPM, this needs to be multiplied by 10:

$$\text{Scaling Multiplier (GPM x 10)} = 0.4$$

S661 Programming

Category	Parameter	Selection	Comments
Output Setup	DIR	UP	Default forward direction.
Rate Setup	MODE	MIN	The 'Minutes' mode achieves the intended timebase.
Rate Setup	SCALE	00.4000	Computed scaling multiplier.
Rate Setup	DP	00000.0	Displaying 1 decimal place.
Rate Setup	OFFSET	00000.0	No offset value, must equal zero.
Output Setup	MODE I	bound	Boundary mode with No latched or timed action.
SetPoint Setup	SP1	00006.0	Relay active at or above 6.0 GPM.
SetPoint Setup	SP2	00075.0	and at or below 75.0 GPM.

Application Expansion

1. Use a Simpson Model S662 Totalizer / Batch Counter to dispense a metered amount of liquid into the shipping containers while accumulating total Gallons shipped. To be used in addition to / separate from the flow rate application.
2. Use a Simpson Model S663 Counter / Rate meter to dispense a metered amount of liquid into the shipping containers while monitoring flow rate.

