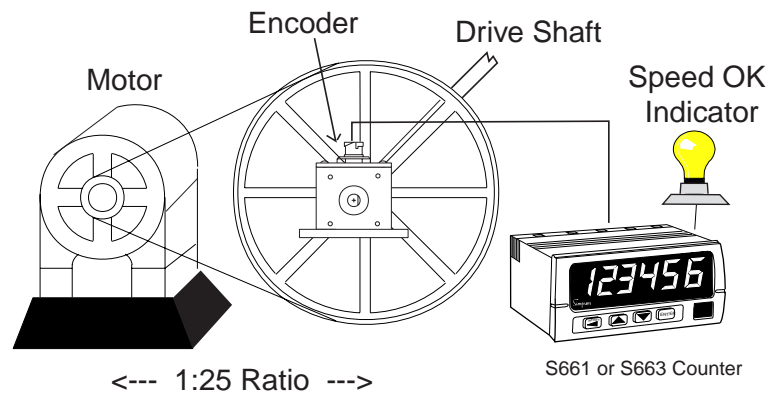

Simpson S66x Counter Series Application Note**AN-6605****Speed Measurement****Technical Level: Beginner****Application Description**

A Simpson Counter and encoder are to be used to measure the speed of a machine drive shaft in RPM.

A lamp is to be activated when the RPM is within a specified operating range.

**Machine Specifications**

Mechanical:	The main drive shaft of the machine has a 3/8" pilot shaft extension available. A motor reducer and drive pulley result in 1 turn of the drive shaft for every 25 motor revolutions. The adjustable speed motor has a top speed of 1725 RPM. The motor and drive shaft direction of travel is not reversible.
Indicator Lamp:	A 120 VAC, 100 Watt light bulb will be used as the 'speed OK' indicator.
Process:	An indicator is to show that the machine is running within the acceptable limits of 40 to 60 RPM.
Display:	Desired display and entry of limits is in RPM with 1 decimal place (###.# RPM).



Product Selection

Rate Counter (Simpson Model **S661**) operating from 120 VAC power has the required capabilities. Since this is a uni-directional application, a standard input card may be used. By adding 12V Excitation to power the encoder and Single Relay Module, counter options have been configured. For mechanical linkage, a 3/8" to 3/8" flexible coupling (Simpson Model **46001**) will safely link the drive shaft extension to the encoder.

When selecting an encoder and counter, initial computations are required to insure that maximum operation speeds will not be exceeded.

$$\text{Max Drive Shaft speed} = \frac{\text{Max Motor Speed}}{\text{Reduction Ratio}} = \frac{1725 \text{ RPM}}{25} = 69 \text{ RPM}$$

Selecting a 60 pulse/turn encoder (Simpson Model **SE-60**):

Encoder output = Drive Shaft Rev/Min x Encoder Pulses/Rev = 69 Rev/Min x 60 Pulses/Rev = 4140 Pulses/Min
 This is well within the counter input frequency rating.

Product Ordering Information

Qty	Simpson Part #	Description																		
1	46001	3/8" to 3/8" flexible coupling.																		
1	SE-60	Quadrature Encoder, 60 pulses per revolution																		
1	S661-1-1-1-1-0	<table border="0" style="width:100%; text-align:center;"> <tr> <td>Model</td> <td>Power</td> <td>Input</td> <td>Output</td> <td>Excitation</td> <td>Other</td> </tr> <tr> <td>↓</td> <td>↓</td> <td>↓</td> <td>↓</td> <td>↓</td> <td>↓</td> </tr> <tr> <td>S661</td> <td>120VAC=1 240VAC=2</td> <td>Standard=1 Quadrature=2</td> <td>None=0 1 Relay=1 2 Relay=2</td> <td>None=0 12 VDC=1</td> <td>None=0</td> </tr> </table>	Model	Power	Input	Output	Excitation	Other	↓	↓	↓	↓	↓	↓	S661	120VAC=1 240VAC=2	Standard=1 Quadrature=2	None=0 1 Relay=1 2 Relay=2	None=0 12 VDC=1	None=0
Model	Power	Input	Output	Excitation	Other															
↓	↓	↓	↓	↓	↓															
S661	120VAC=1 240VAC=2	Standard=1 Quadrature=2	None=0 1 Relay=1 2 Relay=2	None=0 12 VDC=1	None=0															

Hardware Setup :

Since an SE Encoder is being used with a Standard Input card, changes from the default settings will be made. Channel A is set to work with an encoder signal by setting switch positions 4 - 6 to the OFF positions.

Output #1 Normally Open (NO) contact will activate the Lamp.

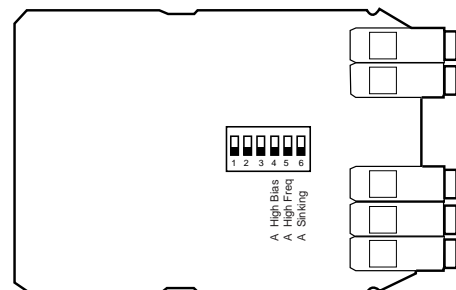

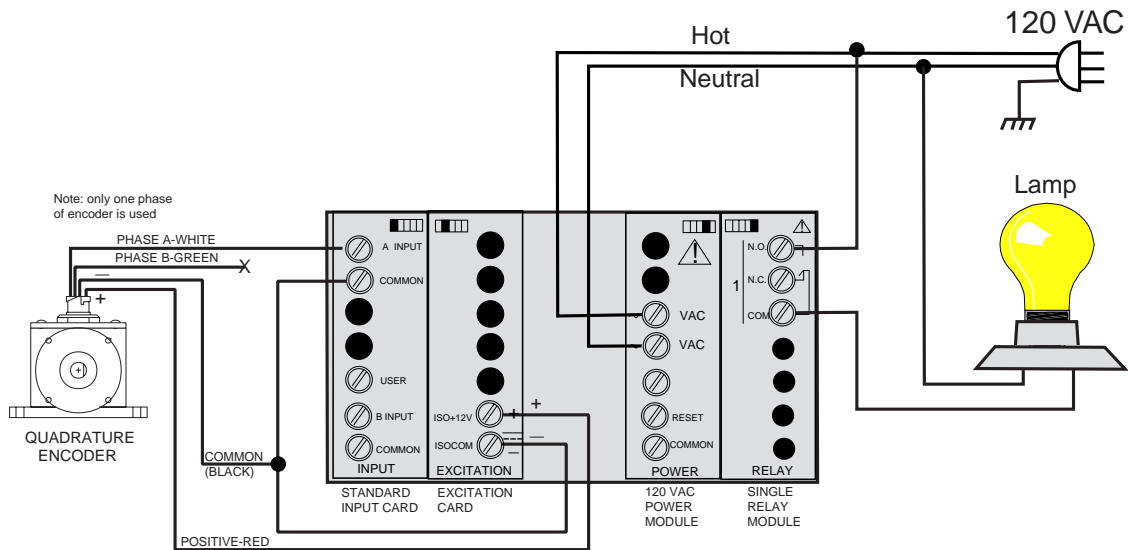

Hardware Setup (Continued)

Counter Programming:

Since the desired rate display is RPM, the Minute mode will be the best choice. Scaling to Shaft RPM from pulses is achieved by taking the inverse of the Encoder Pulses Revolution specification:

$$\text{Scale Factor (RPM)} = \frac{1}{\text{Encoder PPR}} = \frac{1}{60 \text{ Pulses/Rev}} = 0.0166667 \quad (\text{Rev/Pulse})$$

Since the display will be the nearest tenth of RPM, the Scale Factor needs to be multiplied by 10:

$$\text{Scale Factor (RPM x 10)} = \text{Scale Factor (RPM)} \times 10 = \mathbf{0.1667} \quad (\text{Rev/Pulse})$$

The lamp is to be activated whenever the displayed RPM is between 40 and 60. This action is referred to as boundary operation. The Normally Open (NO) relay contact controls the lamp.



S661 Programming

Category	Parameter	Selection	Comments
Input Setup	ACHAN	UP	Default forward direction.
Rate Setup	MODE	MIN	The 'Minutes' mode achieves the intended timebase.
Rate Setup	SCALE	00.1667	Computed scaling multiplier.
Rate Setup	DP	00000.0	Displaying 1 decimal place.
Rate Setup	OFFSET	00000.0	No offset value, must equal zero.
Output 1 Setup	MODE 1	bound	Boundary mode with no latched or timed action.
SetPoint Setup	SP 1	00040.0	Relay active at or above 40.0
SetPoint Setup	SP2	00060.0	and at or below 60.0.

Application Expansion

1. Use a Simpson Model S663 Totalizer / Rate counter to tally machine cycles (which is a multiple of drive shaft turns), while still performing the rate monitoring functions. Use a second output to indicate when a specified number of cycles has occurred, indicating Preventive Maintenance is due.

